

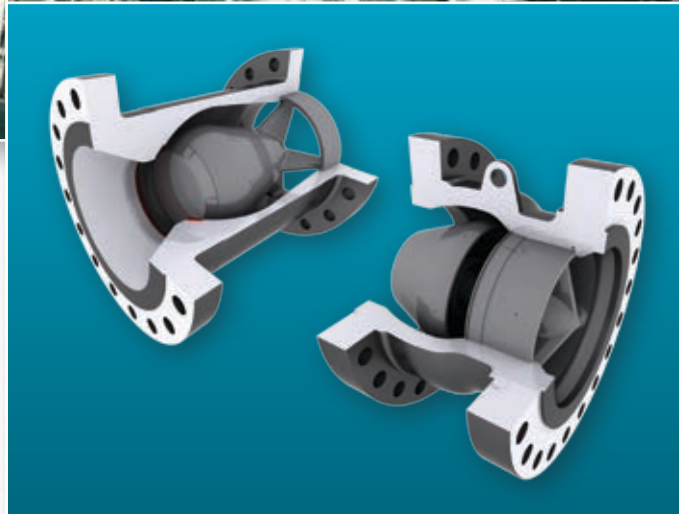

ENTECH

Nozzle check valves

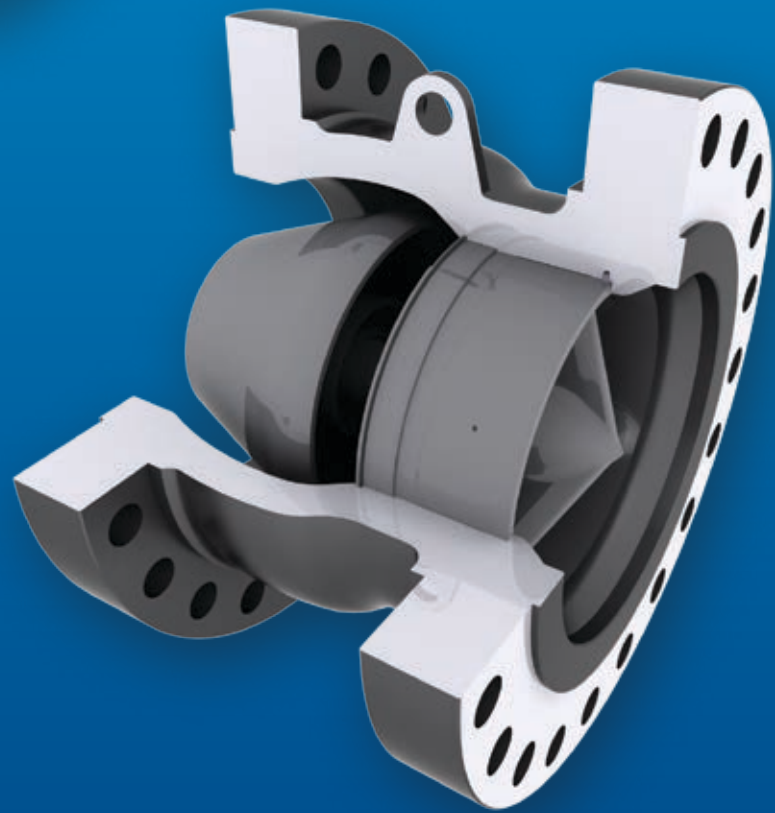

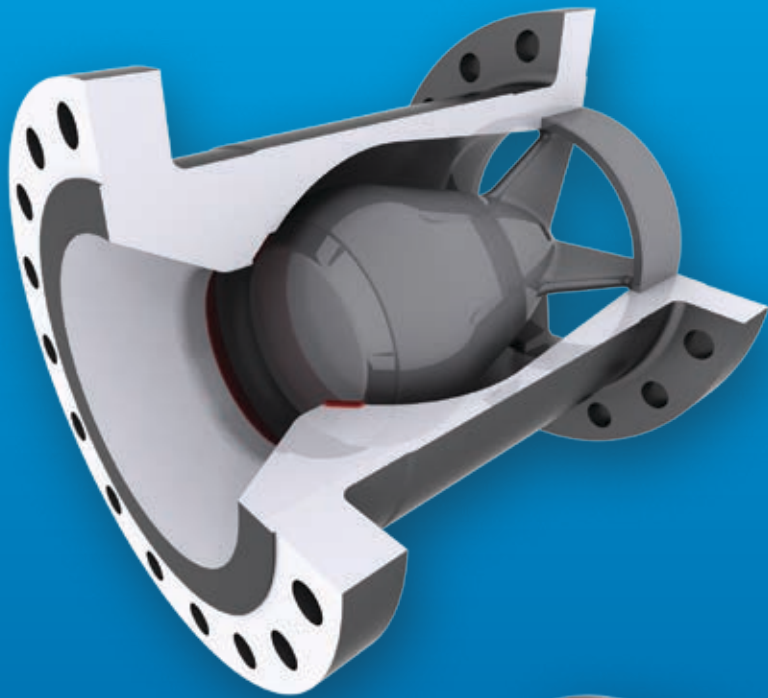

Content

Introduction	4
Features and applications	5
Design and product offerings: DRV-Z	6
Design and product offerings: DRV-BN	7
Quality assurance	8
Dimensional data and weights	8
Flow performance data	8
Materials of construction	9
Design temperatures	9
Installation guidelines	10
Cameron services for valves and actuation	11

ENTECH Nozzle Check Valves



Voghera, Italy

Cameron is a leading provider of valves and measurement systems to the oil and gas industry. Our products are primarily used to control, direct, and measure the flow of oil and gas as it is moved from individual wellheads through flowlines, gathering lines, and transmission systems to refineries, petrochemical plants, and industrial centers for processing.

Cameron provides a wide range of valves for use in natural gas, liquefied natural gas (LNG), crude oil, and refined products transmission lines. The traditional CAMERON T30 Series* fully welded ball valve product line has been combined with the GROVE* valves, RING-O* subsea valves, TOM WHEATLEY* check valves, ENTECH* nozzle check valves, and TK* trunnion-mounted ball valve product lines. This broad offering has strengthened our ability to serve as a single source for customer requirements. Cameron also provides critical service valves for refinery, chemical, and petrochemical processing businesses and for associated storage terminal applications, particularly through the ORBIT* rising stem ball valve and GENERAL* valve lines. These brands are complemented by WKM* valves, TBV* valves, and TEXSTEAM* plug valve products and considerably expand the scope of our product offerings.

ENTECH* nozzle check valves are recognized for their use in pipelines, production, and process applications. The valves are applied primarily in gas compression applications. Nonslam valves prevent reverse flow, and their short stroke length reduces closing time and eliminates water hammer. The pressure loss with a nozzle check valve is minimal and has one of the highest fluid dynamic performances.

Features and Applications

Since 1935, ENTECH nozzle check valves have provided reliable backflow prevention for the oil, gas, water, and process industries. Beginning in 1972, they also served the nuclear industry with nozzle check valves for containment and commercial process.

The ENTECH valve is designed to meet the criteria of conventional check valves by allowing forward flow under normal conditions, opening easily, firmly backseating at low velocity, and closing on reverse flow with minimal seat leakage.

Easy stroking

Very low flow is required to fully open, delivering highest fluid dynamic performance.

Innovative nozzle design

Streamlining the flow results in very low pressure drops and operating costs with no turbulence and vibrations.

Tight shutoff

Metal-to-metal conical seating facilitates perfect self-alignment and minimizes maintenance costs.

Extreme reliability

The SLS* spring-loaded lip seal disc responds quickly to flow variations.

Rapid closing

The valves help to prevent backflow to protect the pipe and critical equipment.

High customizability

The valve is designed to fit almost any application, with internals that can be replaced to suit future flow conditions, and aligned with other Cameron products.

Applications

- Compressor discharge
- Natural gas refineries
- Pump discharge
- Critical equipment discharge
- Compressor and pump bypass
- Storage facilities
- Offshore operations
- Nuclear power plants

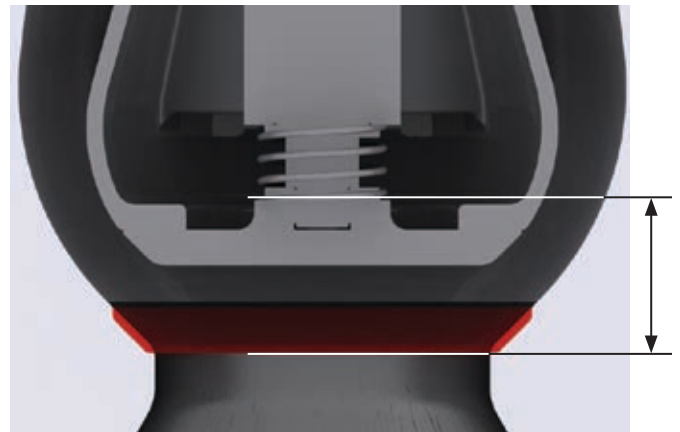

A very low flow velocity is needed to fully open the valve, and the stroke and closure time are short.

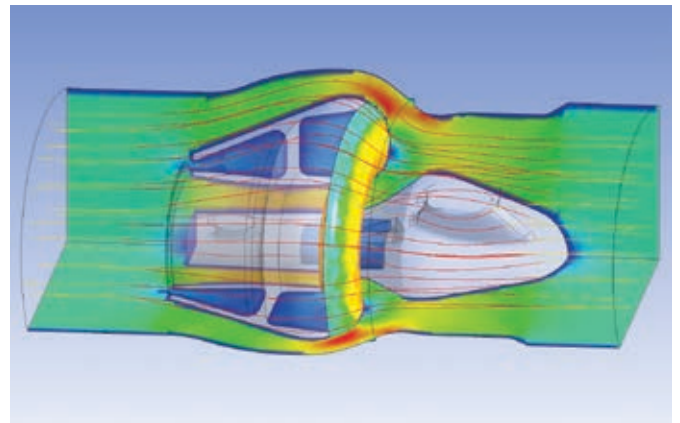

The valves' axial design helps to deliver streamlined flow, low pressure drops, and high-dynamic performances.

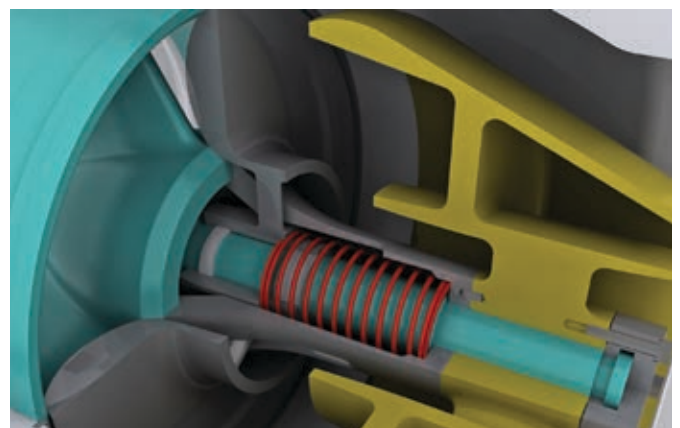

With modular internal components, the valves can be customized to customer needs.

Design and Product Offerings: DRV-Z

The DRV-Z nozzle check valve is a small-bore valve designed for use in piping systems from 1 to 14 in [25 to 350 mm] in diameter. This size range allows the use of a simple, streamlined, in-line check design that is quick to respond to changes in velocity.

The DRV-Z Design also provides

- nonslam closure
- metal seating
- fast closing
- mounting in any orientation
- low pressure drop
- no scheduled maintenance
- tight shutoff.

Sizes and ratings

- Size: 1 to 14 in [25 to 350 mm]
- ANSI/ASME Classes 150–2500
- API 2000–10000
- Face-to-face manufacturers standard
- ANSI/ASME weld-end flanges (other flange-end configurations upon request)
- Other sizes and pressure classes considered upon request

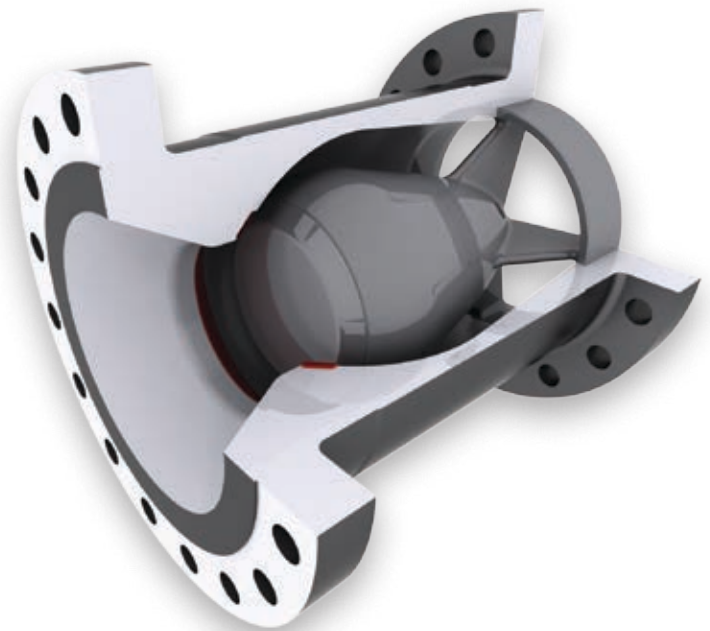

Design and Product Offerings: DRV-BN

The DRV-BN nozzle check valve is a large-bore valve designed for compressor and pumping stations from 16 in [400 mm] in diameter and larger.

In this size range, the ENTECH valve line incorporates

- annular ring design that reduces the weight of the disc to avoid any fatigue phenomena and significantly improve valve response time to pipeline flow changes
- centralized single-coil spring mechanism as the most consistent spring-force design, which is stable and responds rapidly to flow variation
- flowspacer that allows the valve to be fully customizable to specific service and installation conditions and easily reconfigurable in case of potential changes of customer plant flow performances over the years.

The DRV-BN design also provides

- nonslam closure
- metal seating
- fast closing
- spring-loaded disc that allows mounting in any orientation
- low pressure drop
- no scheduled maintenance
- tight shutoff.

Sizes and ratings

- Size: 16 in [400 mm] and larger
- ANSI/ASME Classes 150–2500
- Face-to-face manufacturers standard
- ANSI/ASME weld-end flanges (other flange-end configurations upon request)
- Other sizes and pressure classes considered upon request



Quality Assurance

Cameron operates a high-level QC program to ensure all its products are designed and manufactured to the highest standards using the latest technology. The quality assurance program encompasses our entire operation, from order entry to final inspection and delivery.

Our Lean Six Sigma manufacturing philosophy and the standard warranty, which covers the product for 12 months after installation or

18 months after shipment, whichever occurs first, assures that the design, materials, and workmanship of all ENTECH valves result in years of dependable operation.

Specifications and compliance

ISO 9001:2008, API 6D/ISO 14313, ISO 19001, API 6DSS/ISO 14723, API 6A/ISO 10423, PED, GOST, and CRN.

Dimensional Data and Weights

DRV-Z flanged-end valves

Valve Size		150		300		600		900	
NB	DN	Length, mm	Weight, kg	Length, mm	Weight, kg	Length, mm	Weight, kg	Length, mm	Weight, kg
1	25	100	5	100	5	100	8	100	12
2	50	120	9	120	9	120	11	200	16
3	80	180	16	180	23	180	30	180	32
4	100	240	25	240	38	240	46	240	60
6	150	350	49	350	70	350	97	350	165
8	200	450	88	450	121	450	163	450	241
10	250	500	130	500	177	500	269	500	310
12	300	600	—†	600	—†	600	—†	600	—†
14	350	700	—†	700	—†	700	—†	700	—†

DRV-BN flanged-end valves

16	400	500	385	500	385	500	550	500	640
20	500	625	665	625	665	625	905	665	1,210
24	600	745	1,060	745	1,060	745	1,450	800	2,165
30	750	930	2,040	930	2,040	930	2,640	1,060	3,855
36	900	1,190	3,285	1,190	3,285	1,190	4,340	1,270	6,430
42	1,050	1,308	—†	1,308	—†	1,308	—†	—†	—†
48	1,200	1,485	—†	1,485	—†	1,485	—†	—†	—†

† Information provided upon request.

DRV-Z Flow Performance Data

Size, in	C _v , galUS/min			
	150	300	600	900
1	20	20	20	20
2	84	84	84	84
3	227	227	227	227
4	366	366	366	366
6	881	881	881	881
8	1,692	1,692	1,692	1,692
10	2,762	2,762	2,762	2,762
12	3,043	3,043	3,043	3,043
14	6,003	6,003	6,003	5,952

DRV-BN Flow Performance Data

Size, in	C _v , galUS/min			
	150	300	600	900
16	8,100	8,100	8,100	8,100
20	12,500	12,500	12,500	12,500
24	17,984	17,984	17,984	17,984
30	30,900	30,900	30,900	30,900
36	43,000	43,000	43,000	43,000
42	46,000	46,000	46,000	46,000
48	58,000	58,000	58,000	58,000

Materials of Construction

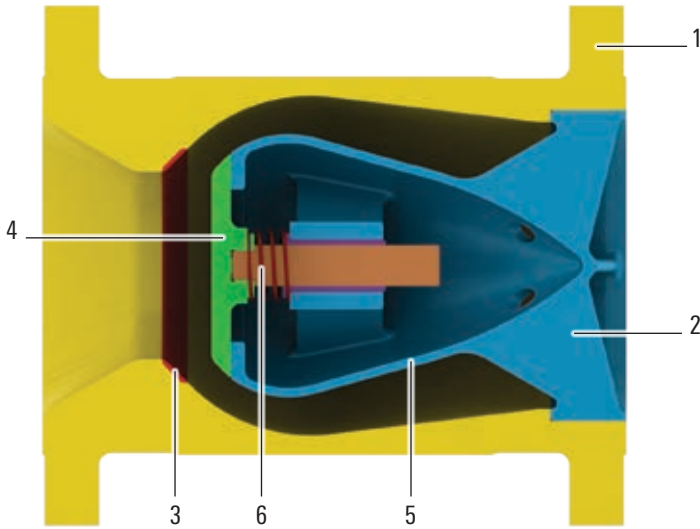

DRV-Z.

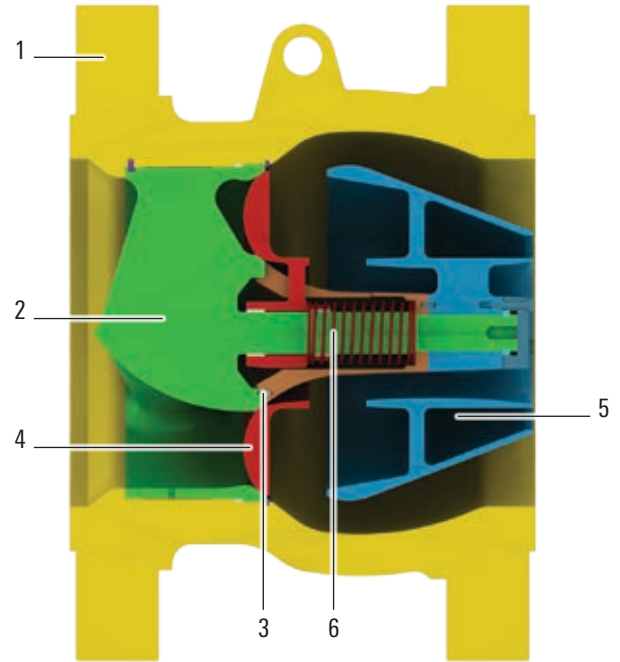

DRV-BN.

Part	Description	Low-Temp. Carbon Steel/316SS Seats	Low-Temp. Carbon Steel/Inco625 Seats	Full Stainless Steel	Full Duplex
1	Body	A352 LCC/A350 LF2	A352 LCC/A350 LF2	A351 CF8M/A182 F316	S31803/A182 F51
2	Nozzle	A352 LCC	A352 LCC	A351 CF8M	S31803
3	Seat	316SS	Inconel® 625	Integral	Integral
4	Disc	A351 CF8M	A351 CF8M	A351 CF8M	S31803
5	Diffuser	A352 LCC	A352 LCC	A351 CF8M	S31803
6	Spring	X-750	X-750	X-750	X-750

Design temperatures

Low-temperature carbon steel: -50 to 572 degF [-45 to 300 degC]

Stainless steel: -320 to 572 degF [-196 to 300 degC]

Duplex: -320 to 572 degF [-196 to 300 degC]

All materials comply with NACE MR0175/ISO 15156 sour service requirements.

Others materials are available upon request to meet specific service requirements.

Applications with temperatures below -50 degF [-45 degC] or exceeding 350 degF [176 degC] are subject to engineering approval.

Installation Guidelines

The nozzle check valve should be installed a minimum of five diameters, and preferably eight diameters, downstream of a flow impediment (valve, reducer, bend, etc.) to ensure a good flow pattern at the entry to the nozzle check valve.

The nozzle check valve also should be installed at least three diameters upstream of a bend or reducer to avoid choked flow conditions, which can prevent the full opening of the check valve.

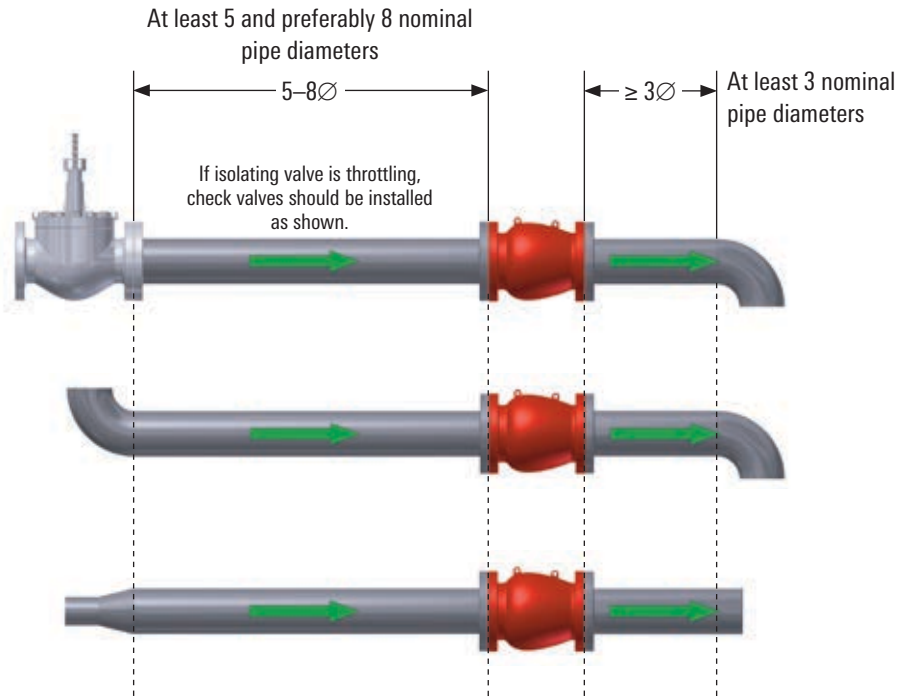

The nozzle check valve can be installed on the upstream side of isolating valves. If the isolating valve is throttling, clearance as shown should be allowed to ensure full pressure recovery after the nozzle check valve.

The nozzle check valve can be installed closer to the inlet of the isolating valve if it is full port and fully open.

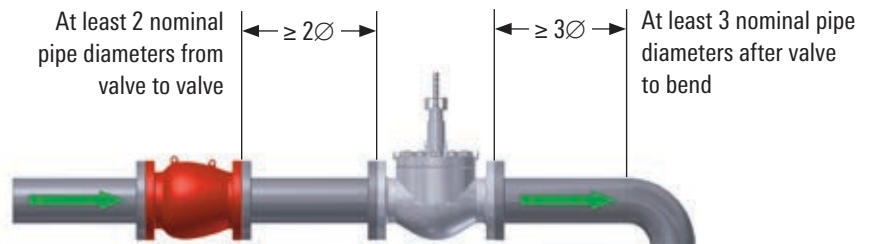

All valve inquiries will require valve datasheets that provide minimum, normal, and maximum operating conditions. Valves must be sized to fully open at minimum operating conditions. The minimum operating conditions refer to what the lowest consistent flow rate will be for an extended period of time. Startup conditions should not be considered as minimum operating conditions.

Aftermarket Services for Valves and Actuation

We build it. We back it.

Cameron is well positioned to quickly and efficiently deliver total aftermarket support with unmatched OEM expertise. Our highly skilled engineers and technicians are available around the clock to respond to customer queries, troubleshoot problems, and offer reliable solutions.

Easily accessible parts and spare valves

- OEM spare valves, actuators, and parts (including non-Cameron brands)
- Handling, storage, packaging, and delivery
- Dedicated stocking program

Comprehensive aftermarket services portfolio

- Parts and spare valves
- Repair
- Field services
- Preventative maintenance
- Equipment testing and diagnostics
- Remanufacturing
- Asset preservation
- Customer property management
- Training and recertification services
- Warranty

Customized total valve care programs

- Engineering consultancy
- Site management
- Flange management
- Startup and commissioning
- Spare parts and asset management
- Operational support



ENTECH



cameron.slb.com/ENTECH

*Mark of Schlumberger
Other company, product, and service names
are the properties of their respective owners.
Copyright © 2016 Schlumberger. All rights reserved. 16-VL-185032

 **CAMERON**
A Schlumberger Company