

NUFLO Gas Turbine Flow Meters

Accurate Gas Flow Measurement

The NUFLO™ Gas Turbine Flow Meter provides accurate gas flow measurement by utilizing a lightweight, low inertia rotor to sense gas velocity. Its output frequency has a linear relationship to gas velocity over a wide flow range.

The meter tracks the flow rate continuously, offers little resistance to flow and has a unique cartridge design that allows removal of all internal parts as one assembly.

The meter exhibits little sensitivity to gas density above two atmospheres pressure. The low inertia of the rotor and vee bearings allows overranging of the meter to twice its rated capacity without damage for intermittent flow variations.

Designed for maximum life, carbide rotor shaft and bearings require no lubrication. The cartridge assembly makes replacement and inspection of parts easy. The meter is designed for installation between two flanges, and is ideal for measurement of fuel gas, production gas, vent gas and flare gas. The digital pulse output can be fed to companion readout devices for direct measurement of flow rate and accumulated throughput.

These measurements can be automatically compensated for pressure and temperature to obtain volumetric measurements in standard units.



Specifications

- **Size** 2" (50.8 mm)
- **Flow Range** 10:1 to 15:1 (see graph, page 2)
- **End Connections** Flow meter installs between two raised face flanges
- **Working Pressure** 0 to 2220 psig (15,306 kPa)
- **Test Pressure** 3330 psig (22,960 kPa)
- **Output Frequency** 0 to 440 Hz nominal
- **Minimum Output Voltage** 30 mV peak to peak at 5 Hz
- **Pressure Drop** Less than 1" (24.5 mm) water column at maximum rated flow
- **Linearity** ± 2% of reading
- **Repeatability** ± 0.5% of reading
- **Temperature** 0° F to 225° F (-18° C to 107° C)
- **Pickup Connector** Mates with AN3106A-10SL-4P
- **Conduit Connection** 1" (25.4 mm)
- **Pressure Tap** 1/8" NPT (3.2 mm)
- **Compliances** CSA Certified Hazardous locations Class I, Div. 1, Groups A, B, C, D
ANSI 12.27.01 single seal
Certified by Cameron in compliance with pre-qualified materials of NACE MR0175/ISO 15156. This certification does not imply or warrant the application of the product in compliance with NACE MR0175/ISO 15156 service conditions in which the customer/user installs the product.

Nominal Calibration Factor

- **Low Range** 325 p/ACF (11477 p/m³)
- **Standard Range** 125 p/ACF (4415 p/m³)
- **High Range** 70 p/ACF (2472 p/m³)

Materials of Construction

- **Body and Cartridge** Grade 316L stainless steel
- **Bearing Mounts** Grade 304 stainless steel
- **Bearings** Tungsten carbide, vee type
- **Rotor** Grade 455 stainless steel, two-bladed
- **Rotor Shaft** Tungsten carbide
- **Snap Rings** Grade 316 stainless steel
- **Set Screws** Grade 304 stainless steel
- **Pressure Port Plug** Grade 304 stainless steel

Installation Hardware

All NUFLO gas meters are supplied with universal ANSI Class 150 to Class 600 centering rings and a pickup coil.

Accessories (optional)

- **Hardware installation kit** containing threaded rods, nuts and gaskets (specify flange rating: ANSI Class 150, 300 or 600)
- **Conduit pickup extension adapter**
- **Flow conditioners**
- **Meter run sections** (specify pressure and flange rating)

Gas Meter Flow Ranges

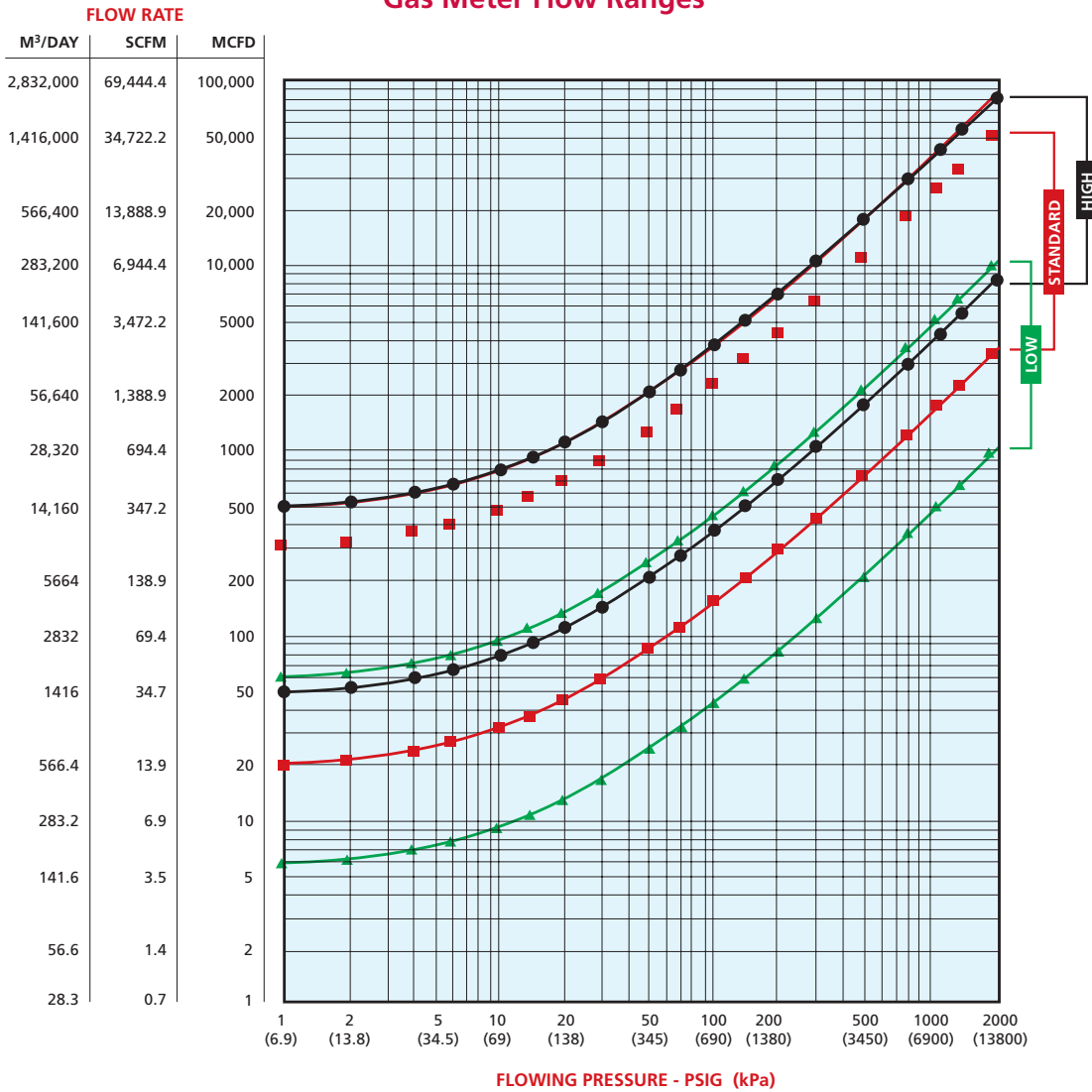

Flow rates are at standard conditions of 14.73 psia and 60° F and are based on 100% methane gas @ 0.6 s.g.

To determine the minimum capacity for other gases use:

$$Q_{(g)} = Q_{(0.6)} \sqrt{\frac{0.6}{G}}$$

$Q_{(0.6)}$ = flow rate on graph
 G = specific gravity of other gas
 $Q_{(g)}$ = flow rate for other gas

For greater accuracy and additional performance information, use Cameron's SizeGas program, available for download from the Cameron (Measurement Systems) website.

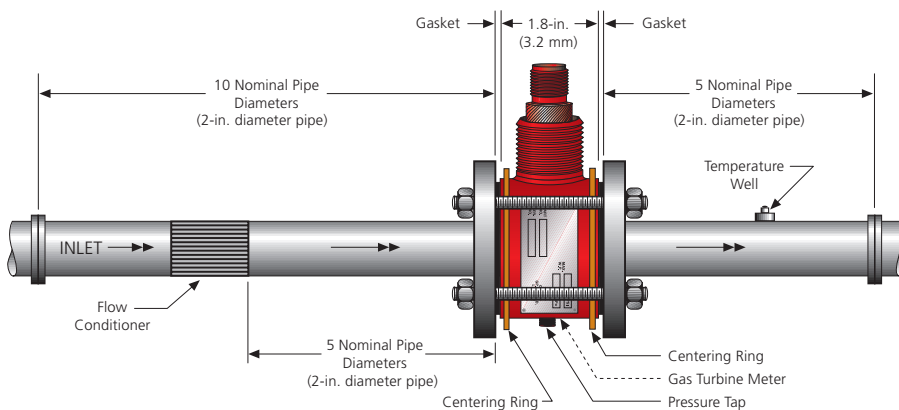

LOCATIONS

North and South America

14450 JFK Blvd.
Houston, TX 77032
USA
Tel 1.281.582.9500
ms-us@c-a-m.com

Europe, Africa, Caspian and Russia

3 Steyning Way
Southern Cross Trading Estate
Bognor Regis
West Sussex PO22 9TT
England, UK
Tel 44.1243.826741
ms-uk@c-a-m.com

Asia Pacific

Suite 16.02 Menara Am Frst
No. 1 Jalan 19/3
46300 Petaling Jaya
Selangor Darul Ehsan
Malaysia
Tel 603.7954.0145
ms-kl@c-a-m.com

Middle East

Level 9, Al Jazira Club Tower A
P.O. Box 47280, Muroor Road
Abu Dhabi
United Arab Emirates
Tel 971.2.596.8400
ms-uk@c-a-m.com

OTHER LOCATIONS

ALGERIA

CANADA

CHINA

INDIA

MALAYSIA

RUSSIA

UAE

UK

USA

www.c-a-m.com/measurement